

D-025 L SB PN 16



Underground Air Valve System for Wastewater

Description

The D-025 L SB is a complete product package that combines the reliable and efficient properties of the A.R.I. D-025 L combination wastewater air valve with the added feature of a sub-surface valve that can be buried below ground. A specifically designed gear box operated horizontal sliding disc valve - situated at the base of the D-025 L SB assembly - allows for the air valve disconnection and maintenance from ground level.

This shut-off valve is equipped with a safety mechanism enabling disconnection and removal of the D-025 L air valve from its subsurface housing, even when the system is under pressure. Since service and maintenance operations of the unit are performed entirely from the surface, there is no need for safety considerations associated with confined space entry.

The D-025 L Combination Air Valve combines an air & vacuum component and an air release component in a single body. The valve is specifically designed to operate with liquids carrying solid particles such as wastewater and effluents. The combination air valve discharges air (gas) during the filling or charging of the system, admits air into the system during drainage and at water column separation and releases accumulated air (gas) from the system while it is operating under pressure. The valve's unique design enables the separation of the liquid from the sealing mechanism and assures optimum working conditions.

Applications

- Wastewater & water treatment plants.
- Wastewater and effluent water transmission lines.

Operation

The air & vacuum component discharges air at high flow rates during the filling of the system and admits air into the system at high flow rates during drainage and at water column separation. High velocity air will not blow the float shut. Water will lift the float which activates the sealing of the valve.

At any time during system operation, should internal pressure of the system fall below atmospheric pressure, air will enter the system. The smooth discharge of air reduces pressure surges and other destructive phenomena.

The intake of air in response to negative pressure protects the system from destructive vacuum conditions and prevents damage caused by water column separation. Air entry is essential to efficiently drain the system.

The air release component releases entrapped air in pressurized systems.

Without air valves, pockets of accumulated air may cause the following hydraulic disturbances:

- Restriction of effective flow due to a reduction of the flow area. In extreme cases this will cause complete flow stoppage.
- Obstruction of efficient hydraulic transmission due to air flow disturbances.
- Acceleration of cavitation damages.
- Increase in pressure transients and surges.
- Internal corrosion of pipes, fittings and accessories.
- Dangerous high-energy bursts of compressed air.
- Inaccuracies in flow metering.

As the system fills and is pressurized, the combination wastewater air valve functions in the following stages:

1. Air (gas) is discharged by the valve.
2. When the liquid level reaches the valve's lower portion, the lower float is lifted, pushing the sealing mechanism to its sealing position.
3. The entrapped air is confined in a pocket between the liquid and the sealing mechanism. The air pressure is equal to the system pressure.
4. Increases in system pressure compress the trapped air in the upper section of the conical chamber. The conical shape assures the height of the air gap. This enables separation of the liquid from the sealing mechanism.
5. Entrapped air (gas), accumulating at peaks and along the system, rises to the top of the valve and displaces the liquid in the valve's body.
6. When the liquid level lowers to a point where the float is no longer buoyant, the float drops, unsealing the rolling seal. The air release orifice opens and allows part of the air that accumulated in the upper portion of the valve to be released to the atmosphere.
7. Liquid enters the valve. The float rises, pushing the rolling seal to its sealing position. The remaining air gap prevents the wastewater from fouling the mechanism.

When internal pressure falls below atmospheric pressure (negative pressure):

1. The floats will drop down, immediately opening the air & vacuum and air release orifices.
2. Air will enter into the system.

Main Features

D-025 L SB Underground Air Valve System for Wastewater:

- The D-025 L SB incorporates an integral, flat, gear box operated horizontal sliding disc valve with a 3" full bore passage.

- The shut-off valve is operated from the surface.
- Easy and efficient back flushing can be achieved while the air valve is in its sub-surface housing.
- All connections utilize quick connectors to facilitate easy usage during:
 1. Handling (quick connector from adaptor to shut-off valve)
 2. Maintenance operations (quick connectors on both the inlet & outlet flushing positions).
- Safety elements: Disengaging the air valve is safeguarded: unless the shut-off valve is in the “closed” position and the internal pressure is released, it is not possible to extract the air valve.
- Pipe connections: 3” threaded (BSP/NPT) or flanged, in accordance with all standards.
- All parts are corrosion resistant: Metal parts made of Stainless Steel, Ductile Iron or Steel, Composite material parts made of Nylon, PA, and PVC

D-025 L Combination Wastewater Air Valve:

- Working pressure range: 0.05 - 16 bar.
- Testing pressure: 25 bar.
- Maximum working temperature: 60° C.
- Maximum intermittent temperature: 90° C.
- A combination air valve for wastewater, with a large air & vacuum orifice and a small air release orifice integrated into one body.
- The unique design of the valve prevents contact between the wastewater and the sealing mechanism by creating an air gap at the top of the valve. These features are achieved by:
 1. **The conical body shape:** designed to maintain the maximum distance between the liquid and the sealing mechanism and still obtain minimum body length.
 2. **Independent spring-guided linkage between the lower float/rod assembly and the upper float sealing mechanism:** allows free movement of the float and rod. Vibrations and movement of the lower float due to turbulence will not unseat the upper float sealing mechanism.
 3. **The Rolling Seal mechanism:** less sensitive to pressure differentials than a direct float seal. It accomplishes this by having a comparably large orifice for a wide pressure range (up to 16 bar).
 4. **Funnel-shaped lower body:** designed to ensure that residue wastewater matter will fall back into the system and be carried away by the main pipe.
- Dynamic design allows for high capacity air discharge while preventing premature closure.
- All inner metal parts made of stainless steel. Float made of composite materials.

Advantages and Benefits

- Relatively lightweight and convenient to install.
- Sub-surface installation.
- Low installation costs:
 1. No need for expensive, large excavation.
 2. No need for expensive, human-accessible manholes.
- Low Maintenance costs:
 1. No need for specialized tools or safety equipment.
 2. One person for operation and maintenance.
 3. Clean and environmentally friendly.
 4. Complete service and maintenance system, including an integral disassembly mechanism to ensure easy back flushing and servicing, while reducing the need for spare changeable valves.
- Safe in operation:
 1. Greatly reduces the danger of contact with local fauna – snakes

- and scorpions, etc.
- 2. Operated and maintained entirely from ground level.
- Reliable and efficient operation:
 1. Dynamic design allows high capacity air discharge while preventing premature closure.
 2. Proven Rolling Seal mechanism.
 3. Since the valve is a sub-surface (underground), it is more resistant to frost conditions.

Valve Selection

- Two different installation lengths:
 1. 800mm tube; complete system length: 970 mm.
 2. 1000mm tube; complete system length: 1170 mm.
- Air valve body: Reinforced nylon, available also in stainless steel.
- Cover and top air valve body: Reinforced nylon, available also in stainless steel.
- Additional Accessories:
 1. With a One-way, Out-only attachment, allows for air discharge only, prevents air intake.
 2. With a Vacuum Breaker, In-only attachment, allows for air intake only, prevents air discharge.
 3. With a Non-Slam discharge-throttling attachment, allows for free air intake, throttles air discharge.

Note

- The D-025 L SB air valve is intended for use with raw wastewater. For use with aggressive liquids, please consult with our application engineers or with the marketing dept.
- For best suitability, it is recommended to send the fluid chemical properties along with the valve request.
- Upon ordering, please specify: model, size, working pressure, thread and flange standard and type of liquid.

UNDERGROUND AIR VALVE SYSTEM PARTS LIST AND SPECIFICATION

No.	Part	Material
1.	Discharge Outlet	Polypropylene
2.	Valve Box Cover	Polyethylene
3.	Lifting Handle	Stainless Steel 304
4.	Ball Valve 1 1/2"	Stainless Steel 304
5.	Pressure Relief Valve	Stainless Steel 316
6.	Back Flushing Assembly	Polyethylene
7.	Operating Rod	Stainless Steel 304
8.	D-025 L Air Valve	see below
9.	Sliding Disc Valve w/ Gear Box	DI+STST+EPDM /STST+STST+EPDM
10.	Adaptor - Quick Connector 3"	Stainless Steel 316
11.	"T" Key	Stainless Steel 304
12.	Safety Handle	Stainless Steel 316
13.	Valve Box	Polyethylene
14.	Flange 3" 4"	Reinforced Nylon /Stainless Steel 316

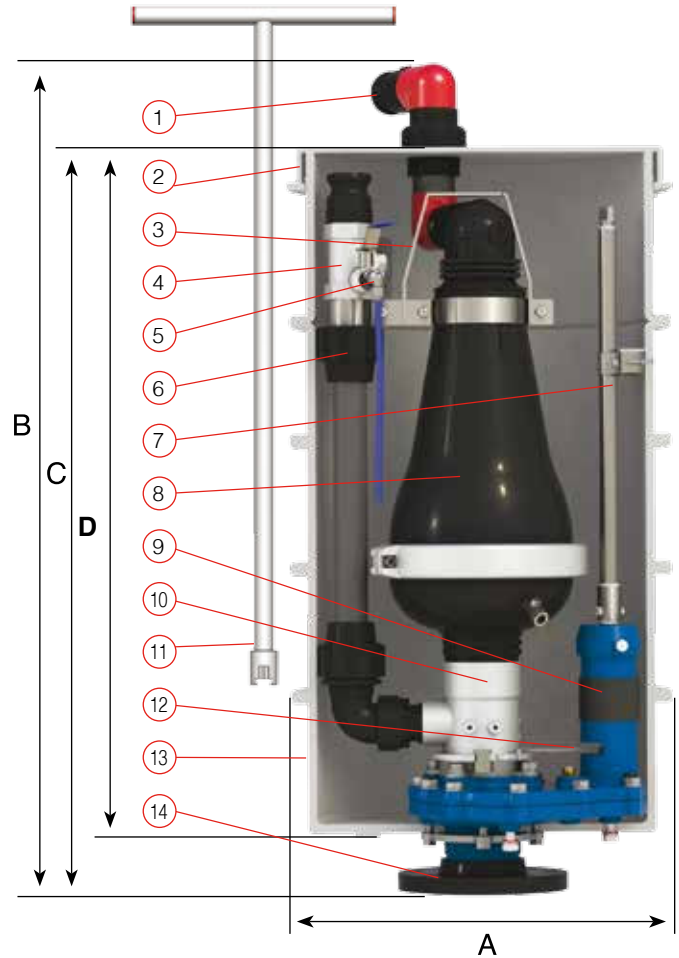

PARTS LIST AND SPECIFICATION

No.	Part	Material
1.	Discharge Outlet	Polypropylene
2.	Rolling Seal Assembly	Reinforced Nylon + E.P.D.M. + Stainless Steel SAE 316
3.	Body	Reinforced Nylon /Stainless Steel SAE 316
4.	Float	Foamed Polypropylene
5.	Clamping Stem	Reinforced Nylon
6.	O-Ring	BUNA-N
7.	Domed Nut	Stainless Steel SAE 316
8.	Stopper	Polypropylene
9.	Spring	Stainless Steel SAE 316
10.	Body	Reinforced Nylon /Stainless Steel SAE 316
11.	Clamp	Stainless Steel ASTM A744 CF8M
12.	O-Ring	BUNA-N
13.	Float Assy.	Polypropylene
14.	Tap 1/4 "	Bronze
15.	Base	Reinforced Nylon /Stainless Steel SAE 316

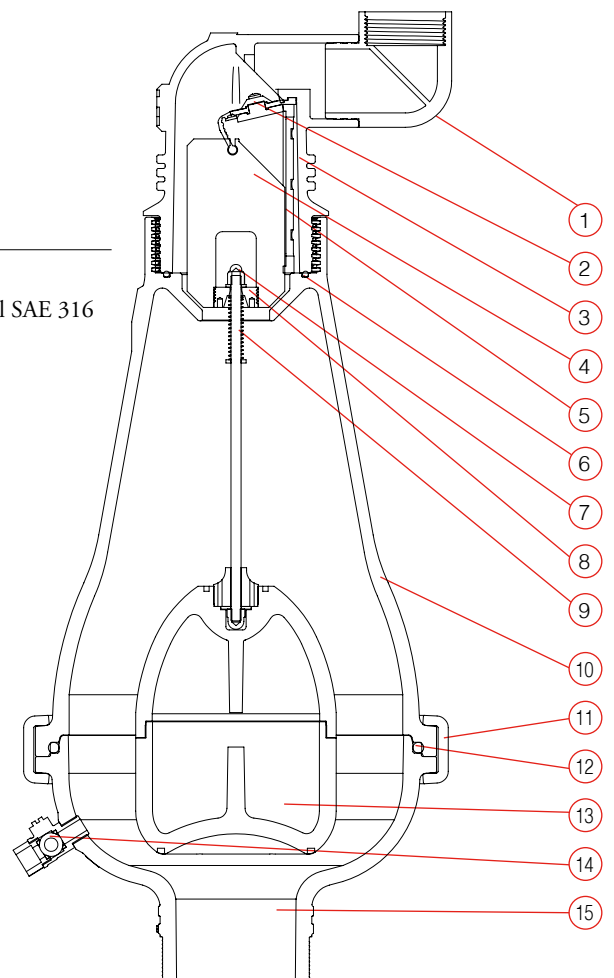

AIR AND VACUUM FLOW RATE

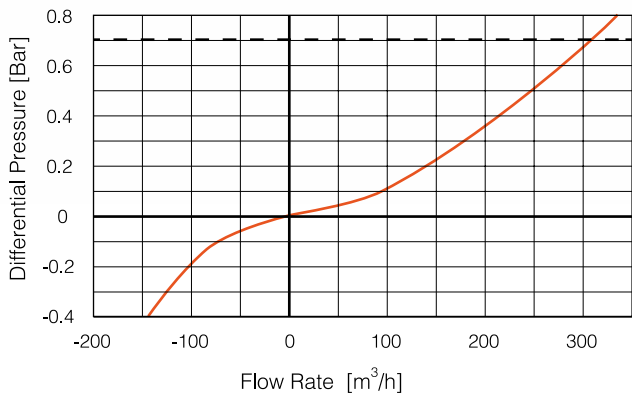

--- Max. recommended design air discharge

AUTOMATIC AIR RELEASE FLOW RATE

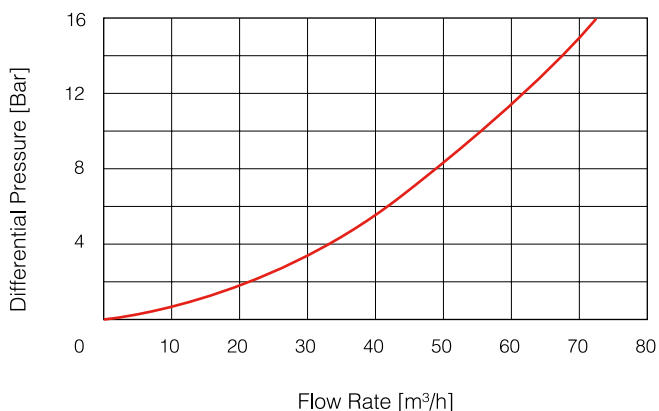

Sample Installation Scheme



Important Information: Prior to site preparation and installation, please refer to the D-025 L SB Installation and Maintenance Manual for all the relevant instructions and information. The manual can be obtained by contacting the A.R.I. marketing dept., from your local A.R.I. distributor or downloading the file from our website.

DIMENSIONS AND WEIGHTS

Model	Dimensions				Weight Kg. RN Body	Orifice Area mm ²	
	A	B	C	D		Auto.	A / V
L800	448	970	875	806	39.3	12	804
L1000	448	1170	1075	1006	42.3	12	804